

HYDRAULIC MOTORS MT

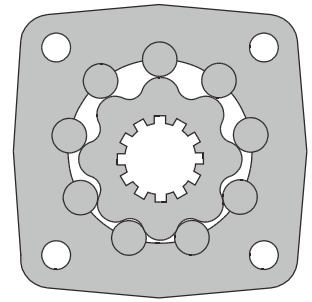

APPLICATION

- » Conveyors
- » Metal working machines
- » Machines for agriculture
- » Road building machines
- » Mining machinery
- » Food industries
- » Special vehicles
- » Plastic and rubber machinery etc.



CONTENTS

Specification data	30
Function diagrams	31 ÷ 33
Dimensions and mounting	34
Shaft extensions	35
Dimensions and mounting- MTS, V	36 ÷ 37
Internal Spline data	38
Permissible shaft loads	38
Tacho connection	39
Order code	39

OPTIONS

- » Model- Disc valve, roll-gerotor
- » Flange with wheel mount
- » Short motor
- » Tacho connection
- » Speed sensing
- » Side and rear ports
- » Shafts- straight, splined and tapered
- » Metric and BSPP ports
- » Other special features

GENERAL

Displacement, [cm ³ /rev.]	161,1 ÷ 523,6
Max. Speed, [RPM]	240 ÷ 625
Max. Torque, [daNm]	47 ÷ 122
Max. Output, [kW]	26,5 ÷ 33,5
Max. Pressure Drop, [bar]	160 ÷ 200
Max. Oil Flow, [l/min]	100 ÷ 125
Min. Speed, [RPM]	5 ÷ 10
Permissible Shaft Loads, [daN]	P _a = 1000
Pressure fluid	Mineral based- HLP(DIN 51524) or HM(ISO 6743/4)
Temperature range, [°C]	-30 ÷ 90
Optimal Viscosity range, [mm ² /s]	20 ÷ 75
Filtration	ISO code 20/16 (Min. recommended fluid filtration of 25 micron)

Oil flow in drain line

Pressure drop (bar)	Viscosity (mm ² /s)	Oil flow in drain line (l/min)
140	20	2,5
	35	1,5
210	20	5
	35	3

Pressure Losses

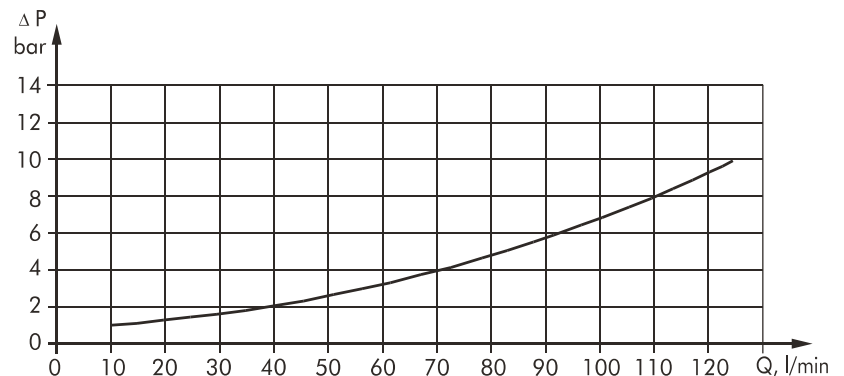

SPECIFICATION DATA

Type	MT 160	MT 200	MT 250	MT 315	MT 400	MT 500	
Displacement [cm ³ /rev.]	161,1	201,4	251,8	326,3	410,9	523,6	
Max. Speed, [RPM]	cont.	625	625	500	380	305	240
	Int.*	780	750	600	460	365	285
Max. Torque [daNm]	cont.	47	59	73	95	108	122
	Int.*	56	71	88	114	126	137
	peak**	66	82	102	133	144	160
Max. Output [kW]	cont.	26,5	33,5	33,5	33,5	30	26,5
	int.*	32	40	40	40	35	30
Max. Pressure Drop [bar]	cont.	200	200	200	200	180	160
	Int.*	240	240	240	240	210	180
	peak**	280	280	280	280	240	210
Max. Oil Flow [l/min]	cont.	100	125	125	125	125	125
	Int.*	125	150	150	150	150	150
Max. Inlet Pressure [bar]	cont.	210	210	210	210	210	210
	Int.*	250	250	250	250	250	250
	peak**	300	300	300	300	300	300
Max. Return Pressure without Drain Line or Max. Pressure in Drain Line , [bar]	cont. 0-100 RPM	75	75	75	75	75	75
	cont. 100-300 RPM	40	40	40	40	40	40
	cont. >300 RPM	20	20	20	20	20	-
Int.* 0-max. RPM	75	75	75	75	75	75	
Max. Return Pressure with Drain Line [bar]	cont.	140	140	140	140	140	140
	Int.*	175	175	175	175	175	175
	peak**	210	210	210	210	210	210
Max. Starting Pressure with Unloaded Shaft, [bar]	10	10	10	10	10	10	
Min. Starting Torque [daNm]	at max. press. drop cont.	34	43	53	74	84	95
	at max. press. drop Int.*	41	52	63	89	97	106
Min. Speed***, [RPM]	10	9	8	7	6	5	
Weight, [kg]	MT	20	20,5	21	22	23	24
	MTW	22	22,5	23	24	25	26
	MTS	15	15,5	16	17	18	19
	MTV	11	11,5	12	13	14	15

* Intermittent operation: the permissible values may occur for max. 10% of every minute.

** Peak load: the permissible values may occur for max. 1% of every minute.

*** For speeds of 5 RPM lower than given, consult factory or your regional manager.

- 1) Intermittent speed and intermittent pressure must not occur simultaneously.
- 2) Recommended filtration is per ISO cleanliness code 20/16. A nominal filtration of 25 micron or better.
- 3) Recommend using a premium quality, anti-wear type mineral based hydraulic oil, HLP(DIN51524) or HM(ISO6743/4).
If using synthetic fluids consult the factory for alternative seal materials.
- 4) Recommended minimum oil viscosity 13 mm²/s at 50°C.
- 5) Recommended maximum system operating temperature is 82°C.
- 6) To assure optimum motor life fill with fluid prior to loading and run at moderate load and speed for 10-15 minutes.

FUNCTION DIAGRAMS

MT 160

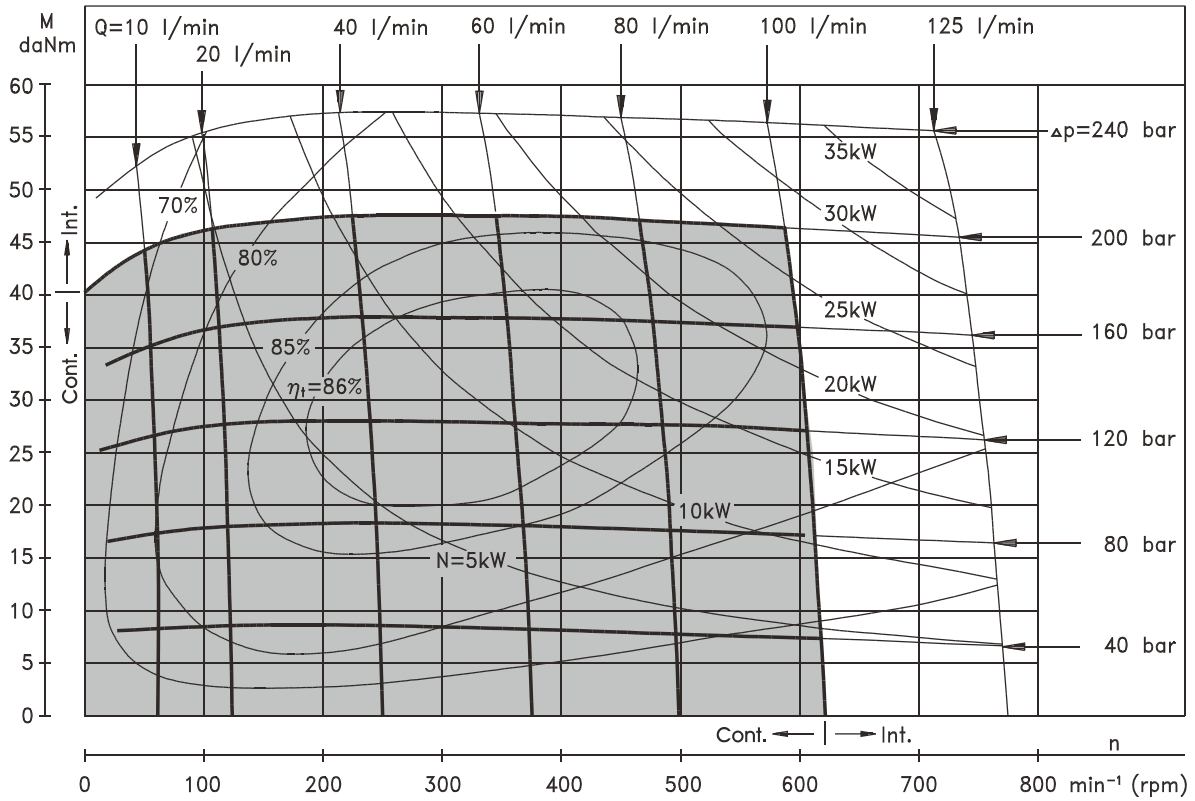

MT 200

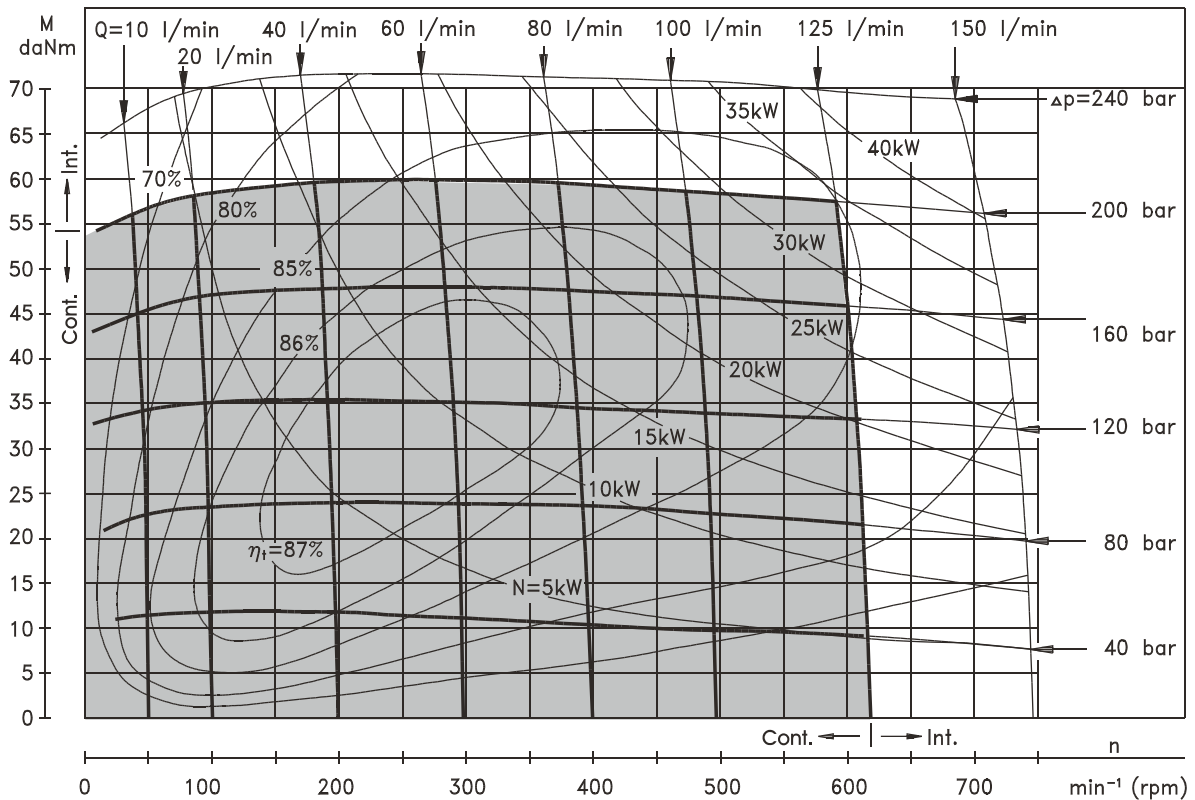

The function diagrams data was collected at back pressure $5 \div 10$ bar and oil with viscosity of $32 \text{ mm}^2/\text{s}$ at 50°C .

FUNCTION DIAGRAMS

MT 250

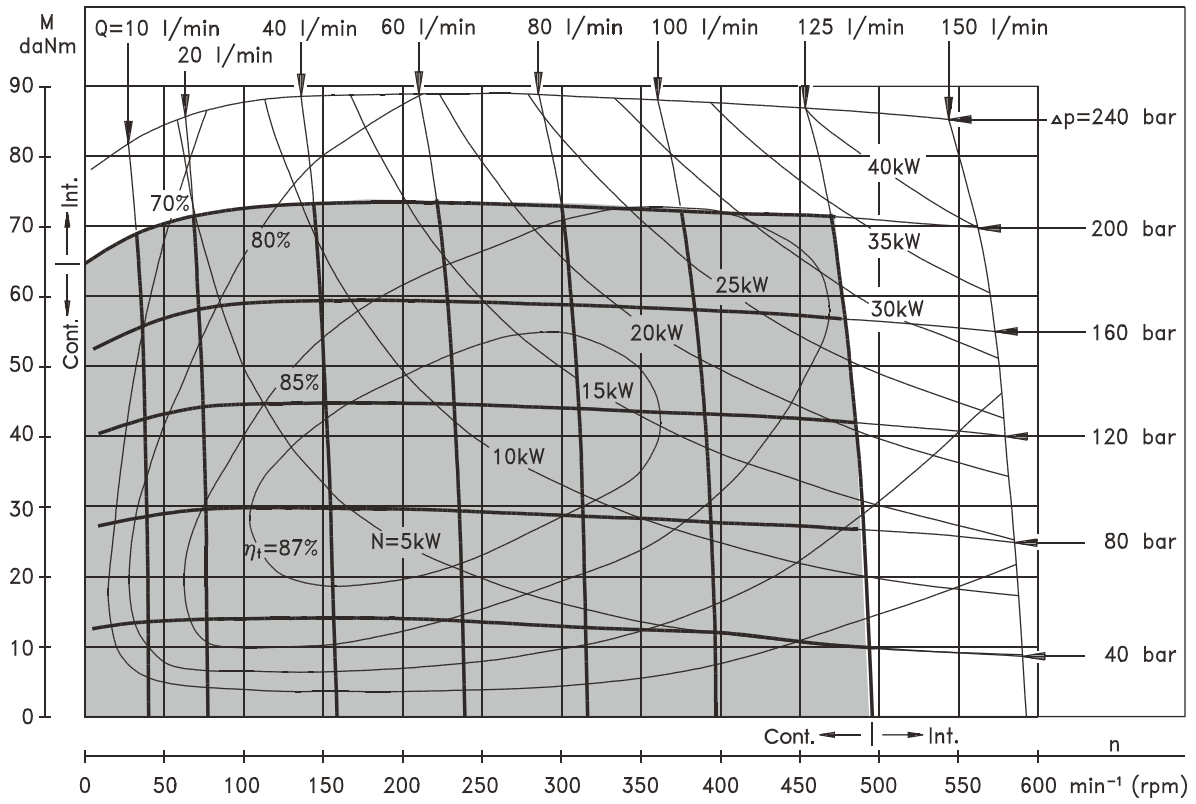

MT 315

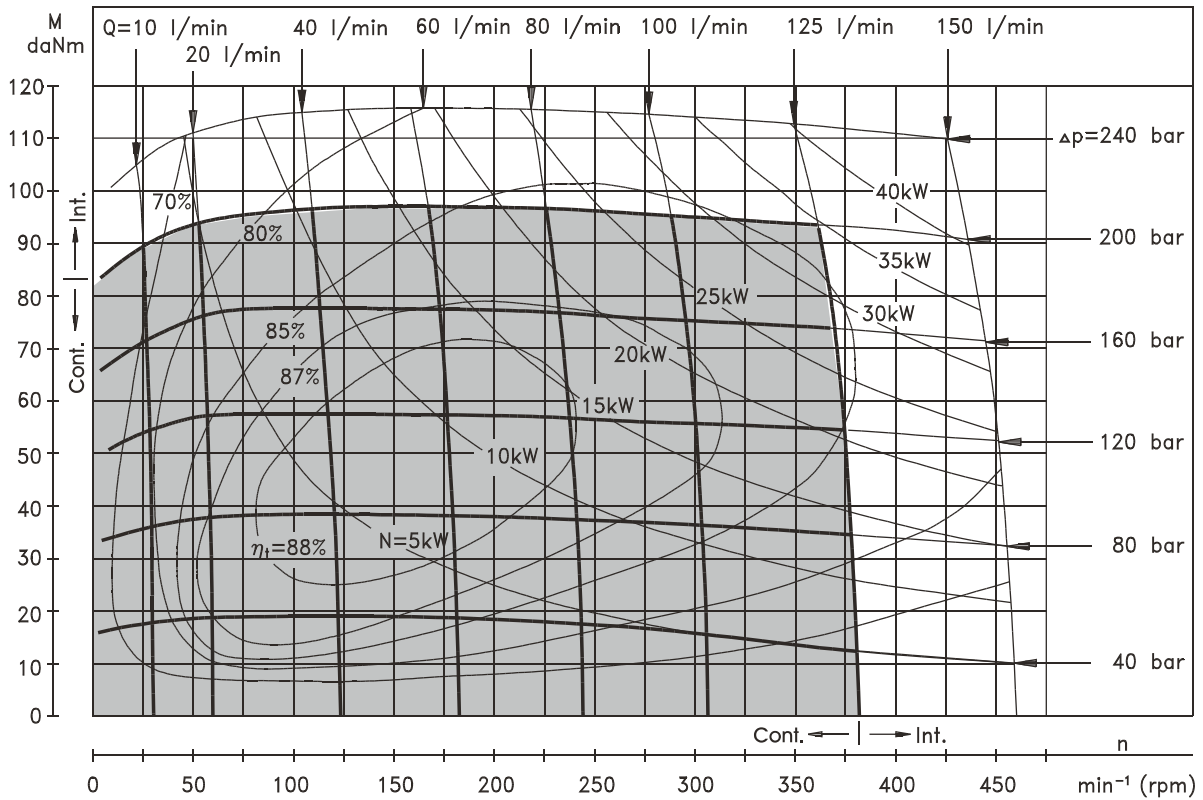

FUNCTION DIAGRAMS

MT 400

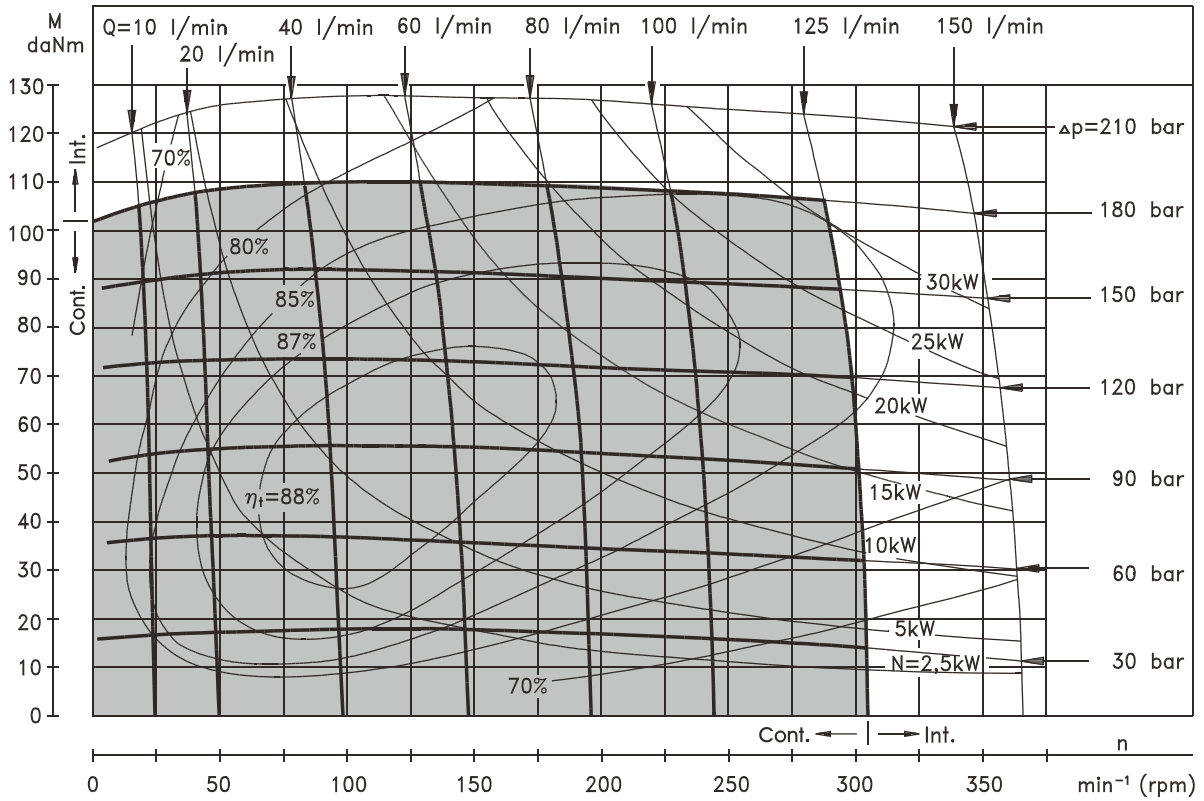

MT 500

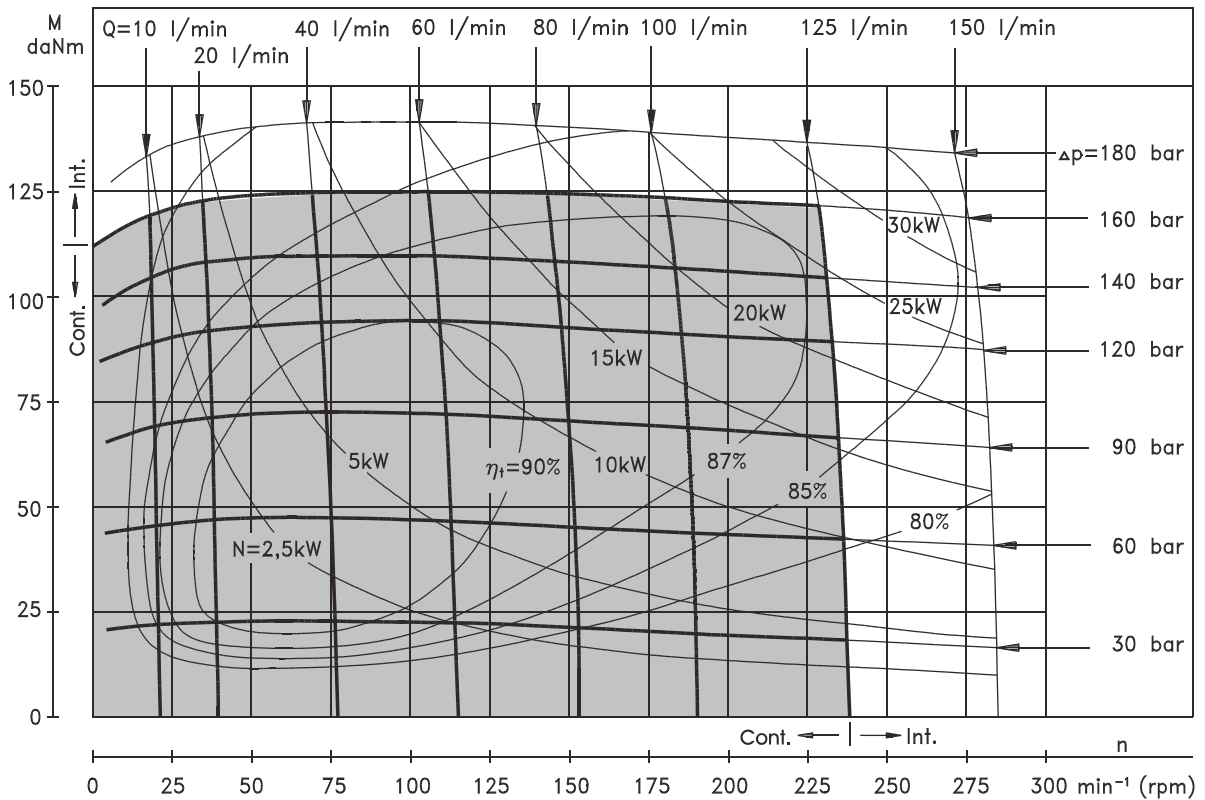

The function diagrams data was collected at back pressure $5 \div 10$ bar and oil with viscosity of $32 \text{ mm}^2/\text{s}$ at 50° C .

SHAFT EXTENSIONS

C - ϕ 40 straight, Parallel key A12x8x70 DIN 6885
Max. Torque 132,8 daNm

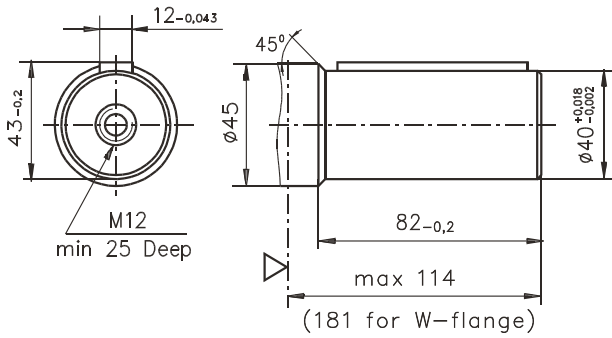

K -tapered 1:10, Parallel key B12x8x28 DIN 6885
Max. Torque 210,7 daNm

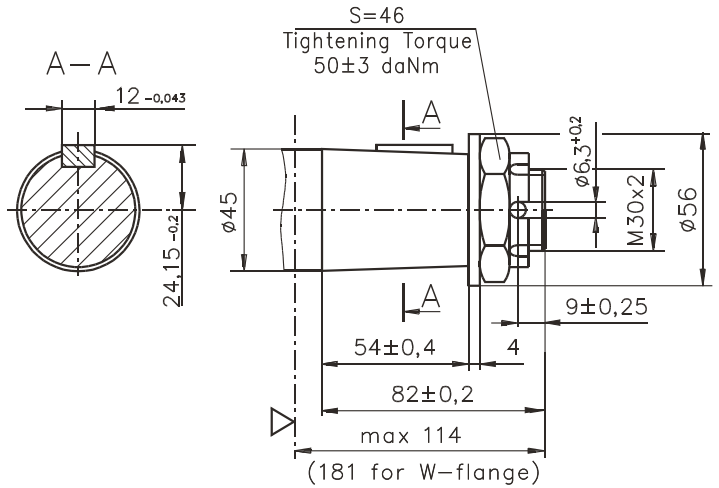

CO - ϕ 1 1/2" straight, Parallel key 3/8" x 3/8" x 2 1/4" BS46
Max. Torque 132,8 daNm

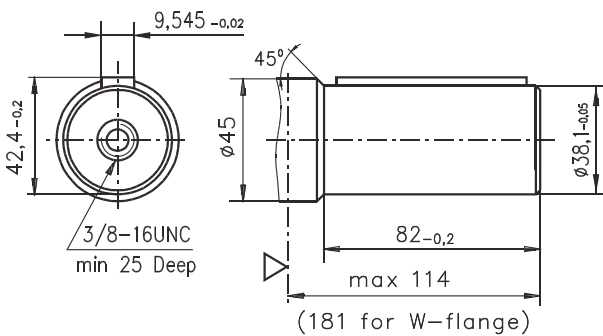

SH - ϕ 1 1/2" splined 17T, DP 12/24 ANSI B92.1-1976
Max. Torque 132,8 daNm

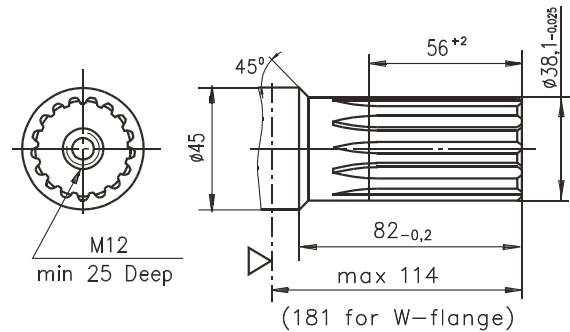

SL - ϕ 34,85 p.t.o. DIN 9611 Form 1
Max. Torque 77 daNm

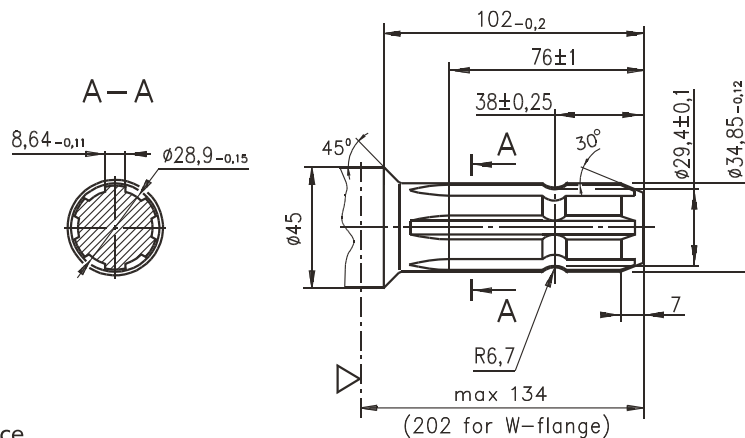

▽ - Motor Mounting Surface

DIMENSIONS AND MOUNTING DATA - MTS and MTV

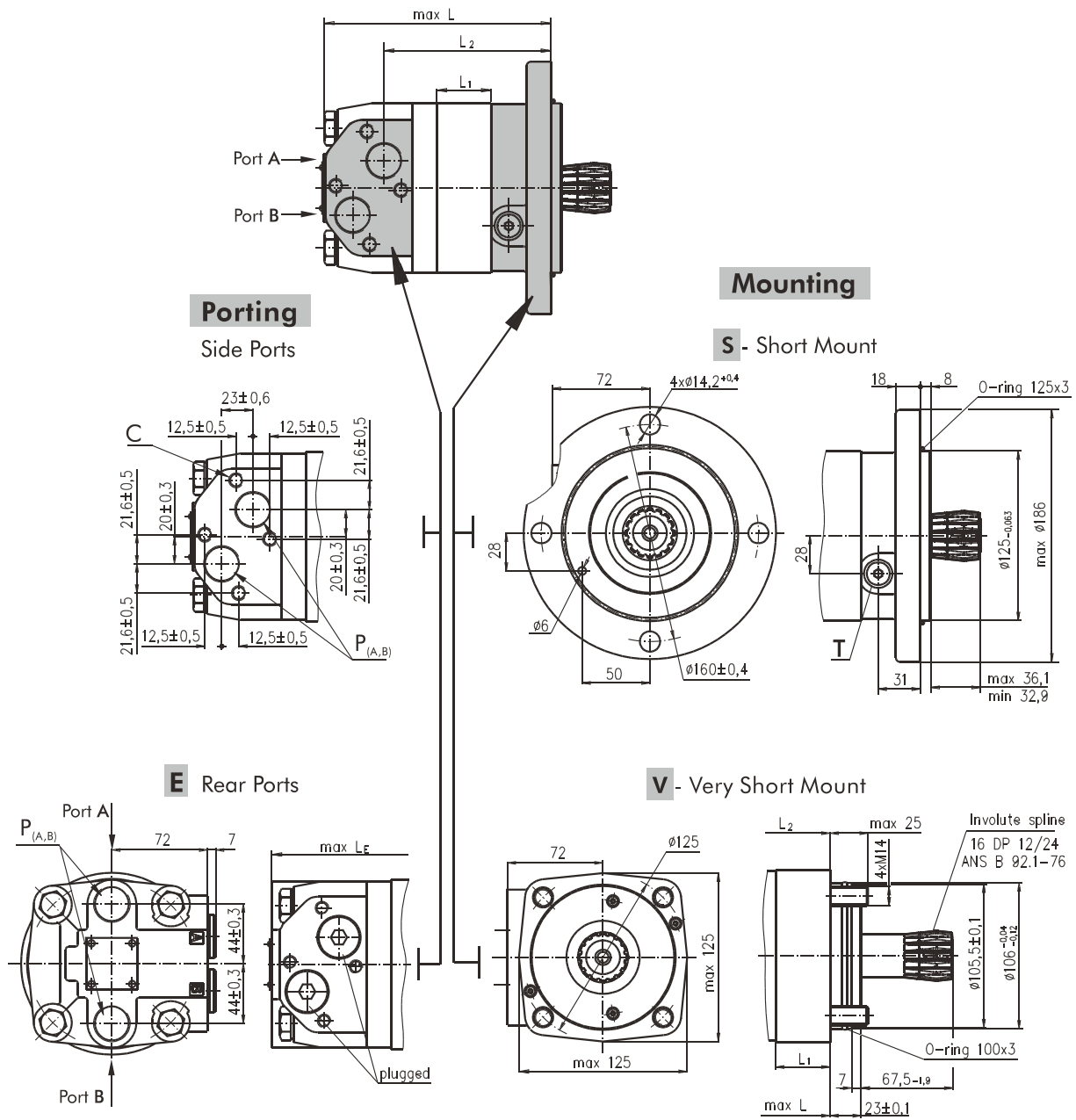

Standard Rotation
Viewed from Shaft End
Port A Pressurized - CW
Port B Pressurized - CCW

Reverse Rotation
Viewed from Shaft End
Port A Pressurized - CCW
Port B Pressurized - CW

C: 4xM10-10 mm depth
P_(A,B): 2xG3/4 or 2xM27x2-17 mm depth
T: G 1/4 or M14x1,5 - 12 mm depth (plugged)

Type	L, mm	Type	L, mm	L ₂ , mm	Type	L, mm	Type	L, mm	L ₂ , mm	L ₁ , mm
MTS 160	151	MTSE 160	156	103	MTV 160	106	MTVE 160	111	58,5	20
MTS 200	156	MTSE 200	161	108	MTV 200	111	MTVE 200	116	63,5	25
MTS 250	162	MTSE 250	167	115	MTV 250	117	MTVE 250	122	70,8	31,3
MTS 315	171	MTSE 315	176	123	MTV 315	126	MTVE 315	131	79	40,5
MTS 400	182	MTSE 400	187	134	MTV 400	137	MTVE 400	142	89,5	51
MTS 500	196	MTSE 500	201	149	MTV 500	151	MTVE 500	156	103,5	65

INTERNAL SPLINE DATA FOR THE ATTACHED COMPONENT

Standard ANSI B92.1-1976, class 5
[$m=2.1166$; corrected $x.m=+1,0$]

Fillet Root Side Fit		mm
Number of Teeth	z	16
Diametral Pitch	DP	12/24
Pressure Angle		30°
Pitch Dia.	D	33,8656
Major Dia.	D _{ri}	38,4 ^{+0,4}
Minor Dia.	D _i	32,15 ^{+0,04}
Space Width [Circular]	Lo	4,516±0,037
Fillet Radius	R	0,5
Max. Measurement between Pin	L	26,9 ^{+0,10}
Pin Dia.	d	4,835±0,001

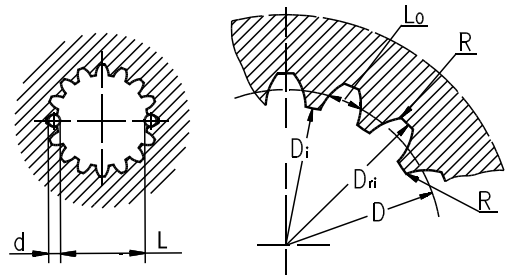

Hardening Specification:
HRC 60±2
HRC 52
0,7±0,2 mm effective case depth
Material 20 MoCr4 DIN 17210 or better

PERMISSIBLE SHAFT LOADS

The output shaft runs in tapered bearings that permit high axial and radial forces. Curve "1" shows max. radial shaft load. Any shaft load exceeding the values quoted in the curve will seriously reduce motor life. The two other curves apply to a B10 bearing life of 3000 hours at 200 RPM.

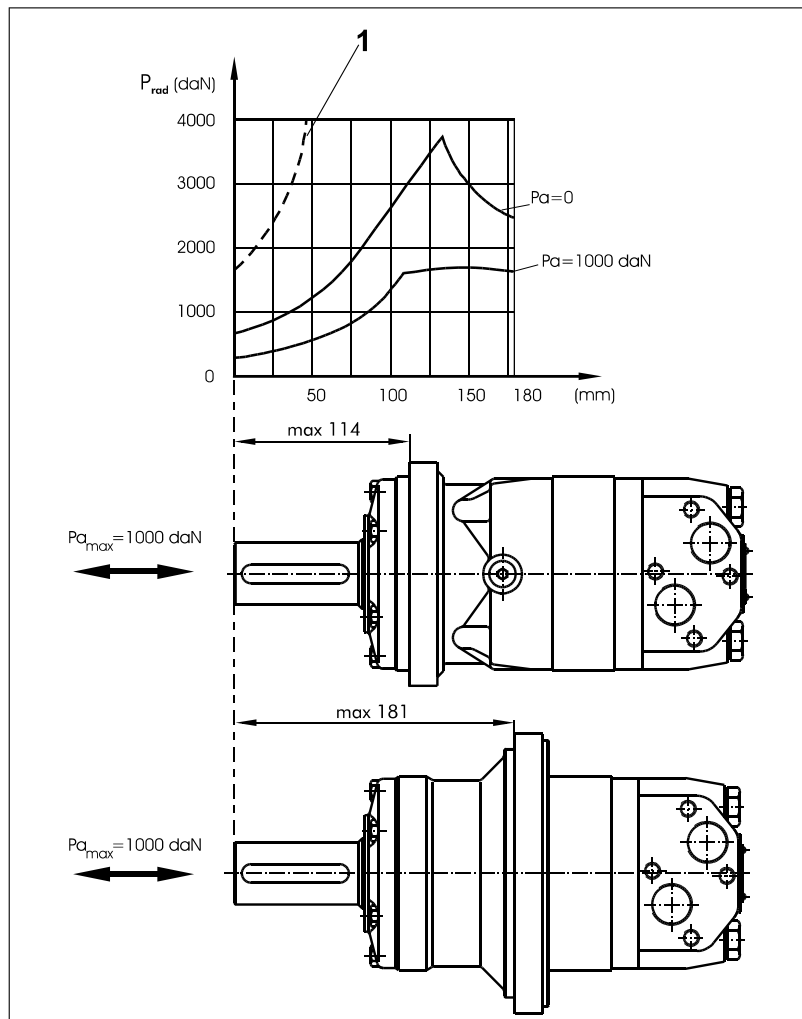

MOTORS WITH TACHO CONNECTION

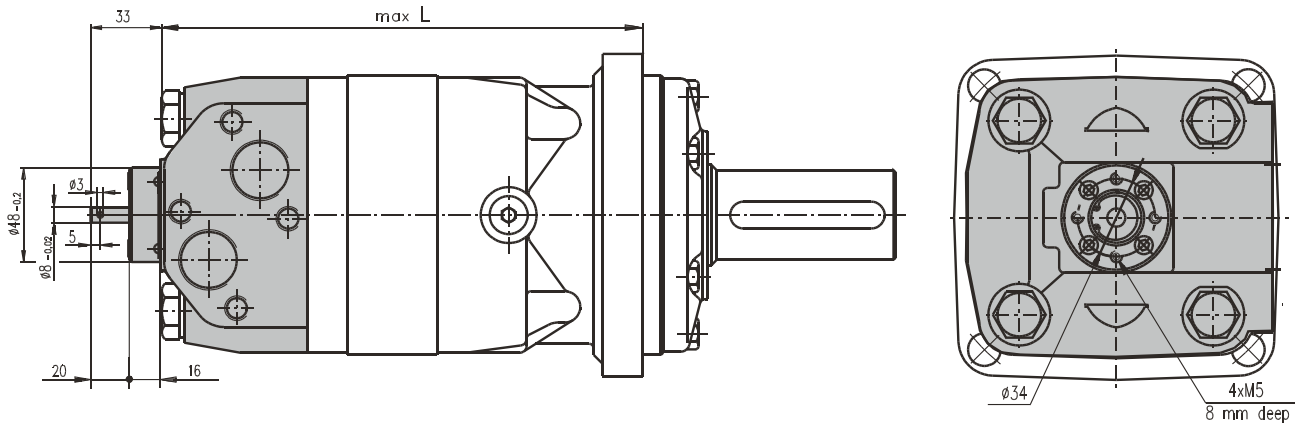

ORDER CODE

	1	2	3	4	5	6	7
M T							

Pos. 1 - Mounting Flange

omit - Square mount, four holes

S - Short mount

V - Very short mount

W - Wheel mount

Pos. 2 - Port type

omit - Side ports

E - Rear ports

Pos. 3 - Displacement code

160 - 161,1[cm³/rev]

200 - 201,4[cm³/rev]

250 - 251,8[cm³/rev]

315 - 326,3[cm³/rev]

400 - 410,9[cm³/rev]

500 - 523,6[cm³/rev]

Pos. 4 - Shaft Extensions*

C - $\varnothing 40$ straight, Parallel key A12x8x70 DIN6885

CO - $\varnothing 1\frac{1}{2}$ " straight, Parallel key $\frac{3}{8}$ "x $\frac{3}{8}$ "x $2\frac{1}{4}$ " BS46

K - $\varnothing 45$ tapered 1:10, Parallel key B12x8x28 DIN6885

SL - $\varnothing 34,85$ p.t.o. DIN 9611 Form 1

SH - $\varnothing 1\frac{1}{2}$ " splined 17T ANSI B92.1-1976

Pos. 5 - Ports

omit - BSPP (ISO 228)

M - Metric (ISO 262)

Pos. 6 - Special Features (see page 50)

Pos. 7 - Design Series

omit - Factory specified

NOTES:

* The permissible output torque for shafts must not be exceeded!

The hydraulic motors are mangano-phosphatized as standard.

HYDRAULIC MOTORS MV



APPLICATION

- » Conveyors
- » Metal working machines
- » Machines for agriculture
- » Road building machines
- » Mining machinery
- » Food industries
- » Special vehicles
- » Plastic and rubber machinery etc.

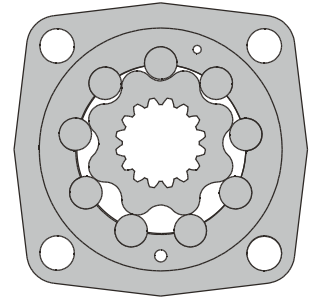

CONTENTS

Specification data	41
Function diagrams	42 ÷ 44
Permissible shaft loads	44
Dimensions and mounting	45
Dimensions and mounting- MVS	46
Dimensions and mounting- MVV	47
Internal Spline data	48
Tacho connection	48
Shaft extensions	49
Order code	49

OPTIONS

- » Model- Disc valve, roll-gerotor
- » Flange and wheel mount
- » Short motor
- » Tacho connection
- » Speed sensing
- » Side ports
- » Shafts- straight, splined and tapered
- » Metric and BSPP ports
- » Other special features

GENERAL

Displacement, [cm ³ /rev.]	314,5 ÷ 801,8
Max. Speed, [RPM]	250 ÷ 510
Max. Torque, [daNm]	92 ÷ 188
Max. Output, [kW]	42,5 ÷ 53,5
Max. Pressure Drop, [bar]	160 ÷ 200
Max. Oil Flow, [l/min]	160 ÷ 200
Min. Speed, [RPM]	5 ÷ 10
Permissible Shaft Loads, [daN]	P ₀ = 1500
Pressure fluid	Mineral based- HLP(DIN 51524) or HM(ISO 6743/4)
Temperature range, [°C]	-30 ÷ 90
Optimal Viscosity range, [mm ² /s]	20 ÷ 75
Filtration	ISO code 20/16 (Min. recommended fluid filtration of 25 micron)

Oil flow in drain line

Pressure drop (bar)	Viscosity (mm ² /s)	Oil flow in drain line (l/min)
140	20	3
	35	2
210	20	6
	35	4

Pressure Losses

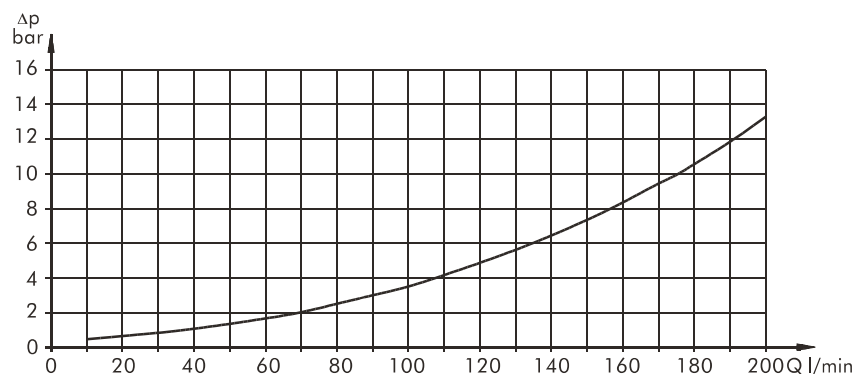

SPECIFICATION DATA

Type		MV 315	MV 400	MV 500	MV 630	MV 800
Displacement [cm ³ /rev.]		314,5	400,9	499,6	629,1	801,8
Max. Speed, [RPM]	cont.	510	500	400	315	250
	Int.*	630	600	480	380	300
Max. Torque [daNm]	cont.	92	118	146	166	188
	Int.*	111	141	176	194	211
	peak**	129	164	205	221	247
Max. Output [kW]	cont.	42,5	53,5	53,5	48	42,5
	int.*	51	64	64	56	48
Max. Pressure Drop [bar]	cont.	200	200	200	180	160
	Int.*	240	240	240	210	180
	peak**	280	280	280	240	210
Max. Oil Flow [l/min]	cont.	160	200	200	200	200
	Int.*	200	240	240	240	240
Max. Inlet Pressure [bar]	cont.	210	210	210	210	210
	Int.*	250	250	250	250	250
	peak**	300	300	300	300	300
Max. Return Pressure without Drain Line or Max. Pressure in Drain Line , [bar]	cont. 0-100 RPM	60	60	60	60	60
	cont. 100-300 RPM	30	30	30	30	30
	cont. >300 RPM	20	20	20	20	20
Int.* 0-max. RPM	75	75	75	75	75	
Max. Return Pressure with Drain Line [bar]	cont.	140	140	140	140	140
	Int.*	175	175	175	175	175
	peak**	210	210	210	210	210
Max. Starting Pressure with Unloaded Shaft, [bar]		8	8	8	8	8
Min. Starting Torque [daNm]	at max. press. drop cont.	71	91	113	133	151
	at max. press. drop Int.*	85	109	136	155	170
Min. Speed***, [RPM]		10	9	8	6	5
Weight, avg. [kg]	MV	31,8	32,6	33,5	34,9	36,5
	MVW	32,4	33,2	34,1	35,5	37,1
	MVS	22,7	23,5	24,4	25,6	27,7

* Intermittent operation: the permissible values may occur for max. 10% of every minute.

** Peak load: the permissible values may occur for max. 1% of every minute.

*** For speeds of 5 RPM lower than given, consult factory or your regional manager.

- 1) Intermittent speed and intermittent pressure must not occur simultaneously.
- 2) Recommended filtration is per ISO cleanliness code 20/16. A nominal filtration of 25 micron or better.
- 3) Recommend using a premium quality, anti-wear type mineral based hydraulic oil, HLP(DIN51524) or HM(ISO6743/4).
If using synthetic fluids consult the factory for alternative seal materials.
- 4) Recommended minimum oil viscosity 13 mm²/s at 50°C.
- 5) Recommended maximum system operating temperature is 82°C.
- 6) To assure optimum motor life fill with fluid prior to loading and run at moderate load and speed for 10-15 minutes.

FUNCTION DIAGRAMS

MV 315

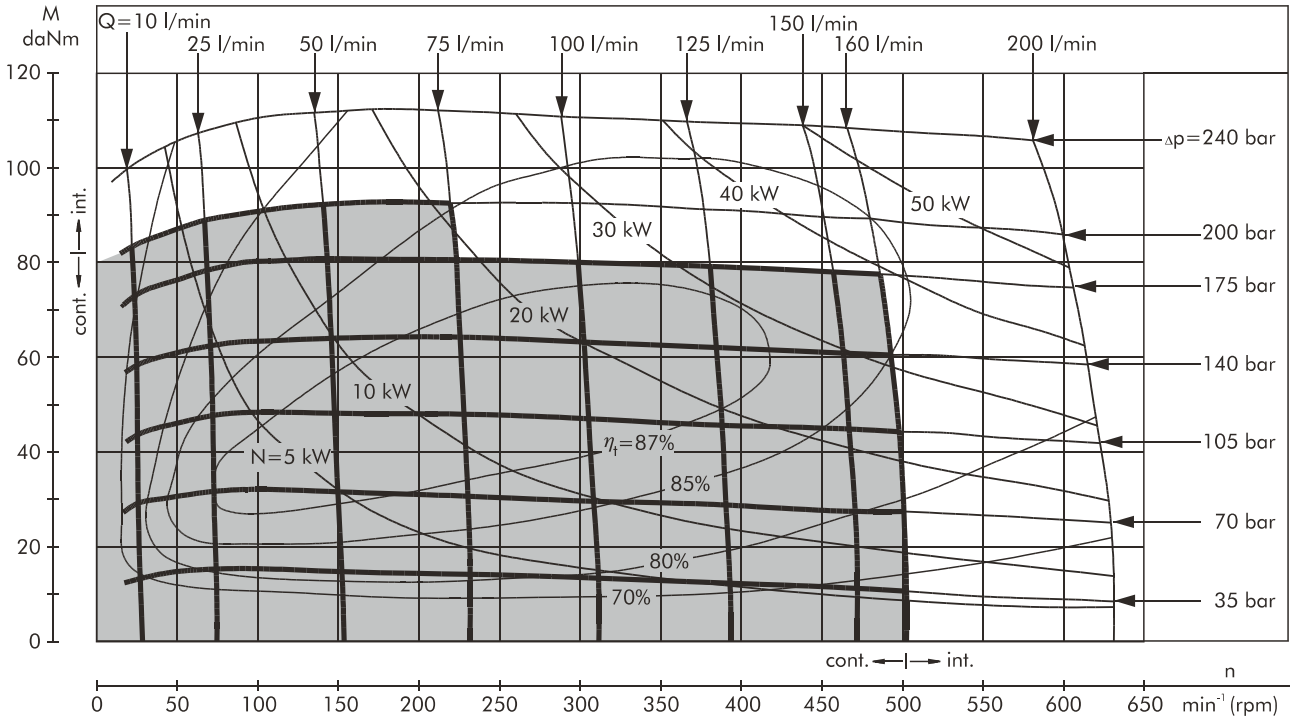

MV 400

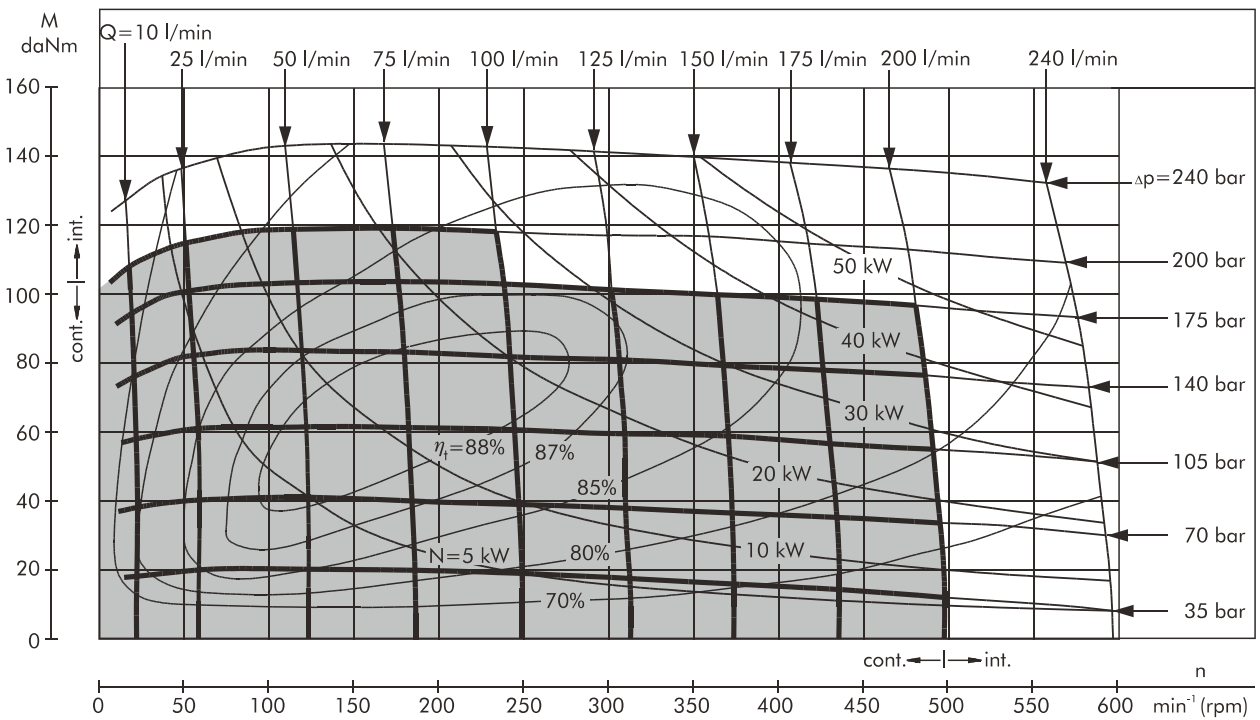

The function diagrams data was collected at back pressure 5 ÷ 10 bar and oil with viscosity of 32 mm²/s at 50° C.

FUNCTION DIAGRAMS

MV 500

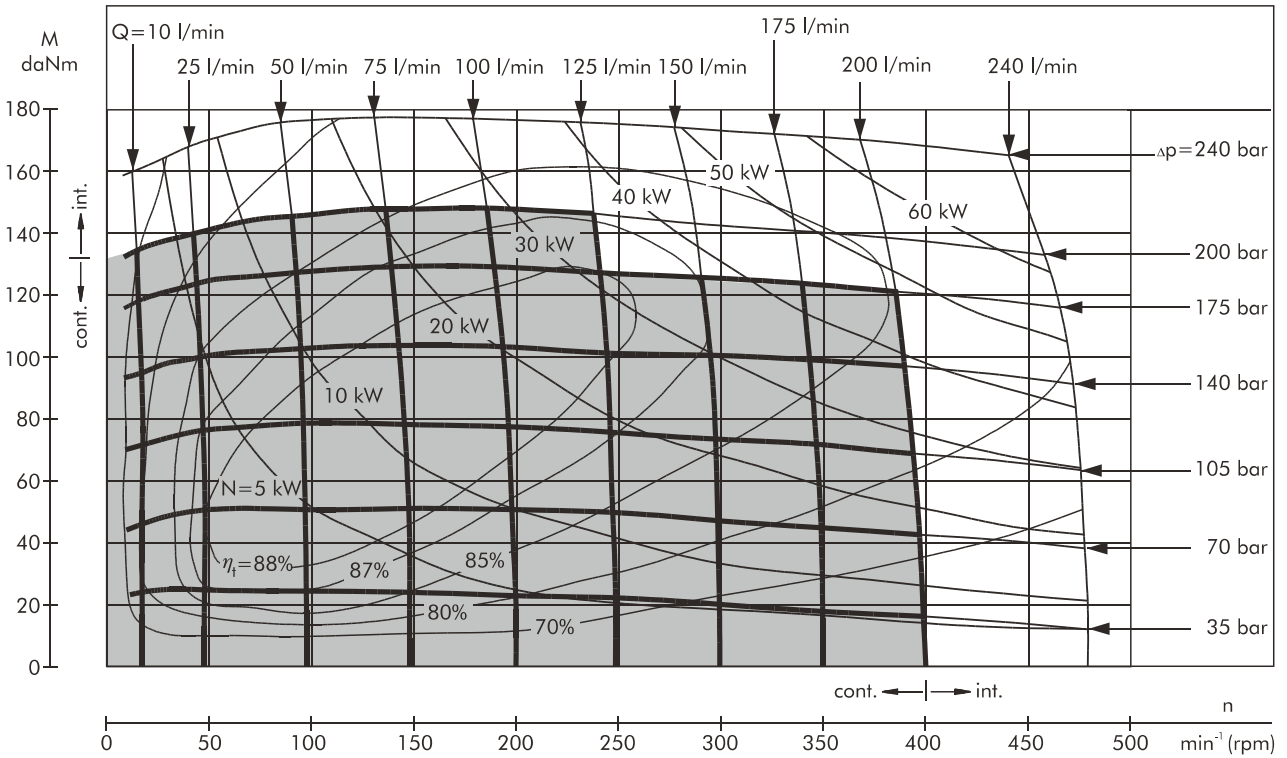

MV 630

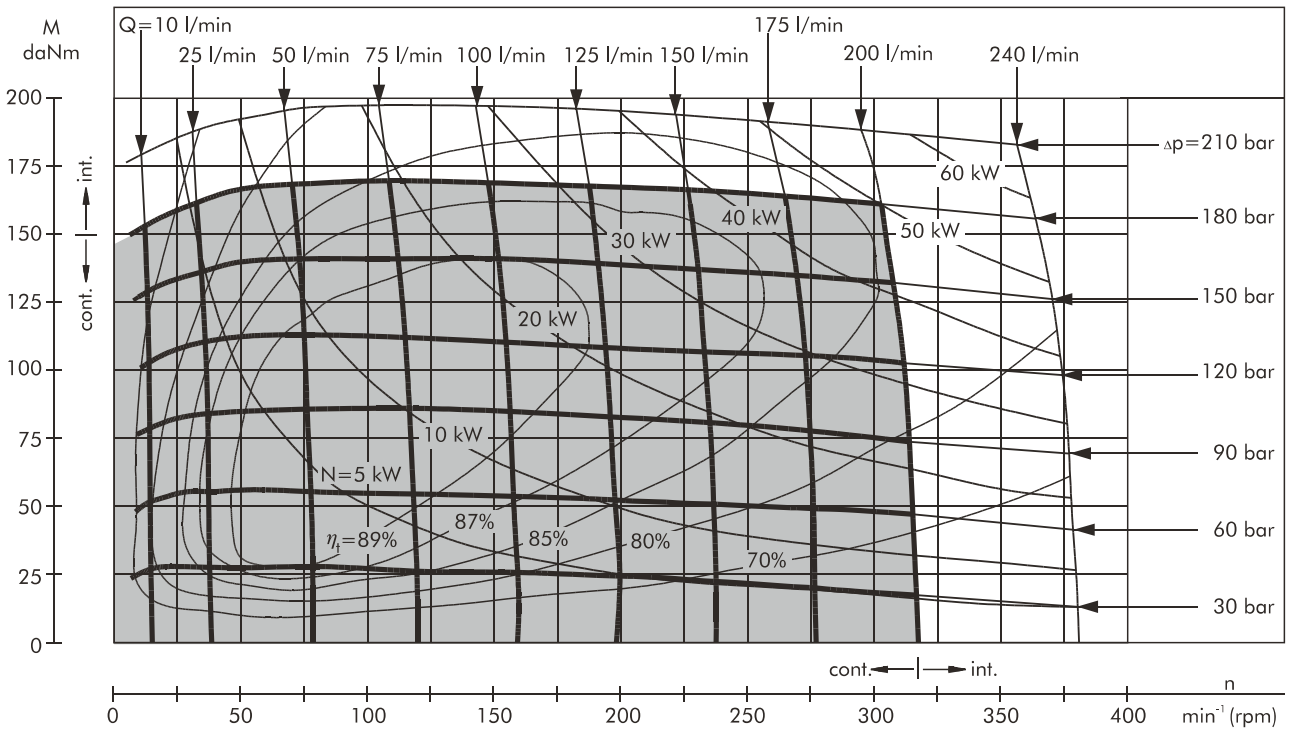

The function diagrams data was collected at back pressure 5 ÷ 10 bar and oil with viscosity of 32 mm²/s at 50° C.

FUNCTION DIAGRAMS

MV 800

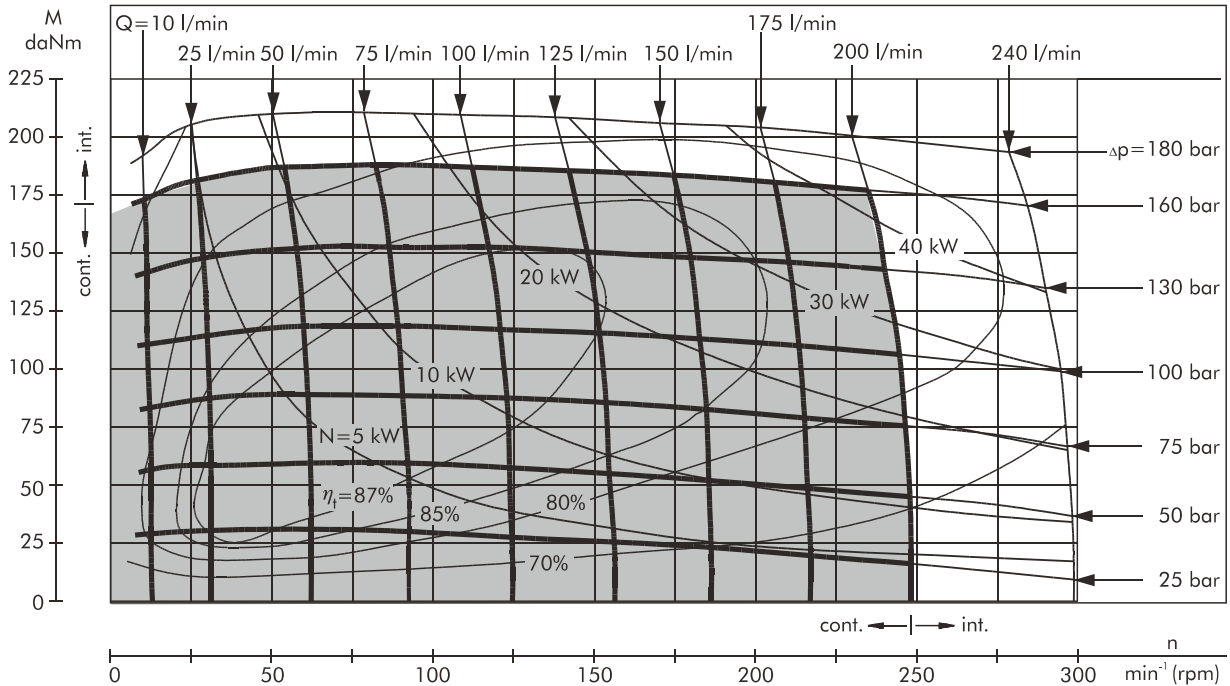

The function diagrams data was collected at back pressure 5 ÷ 10 bar and oil with viscosity of 32 mm²/s at 50° C.

PERMISSIBLE SHAFT LOADS

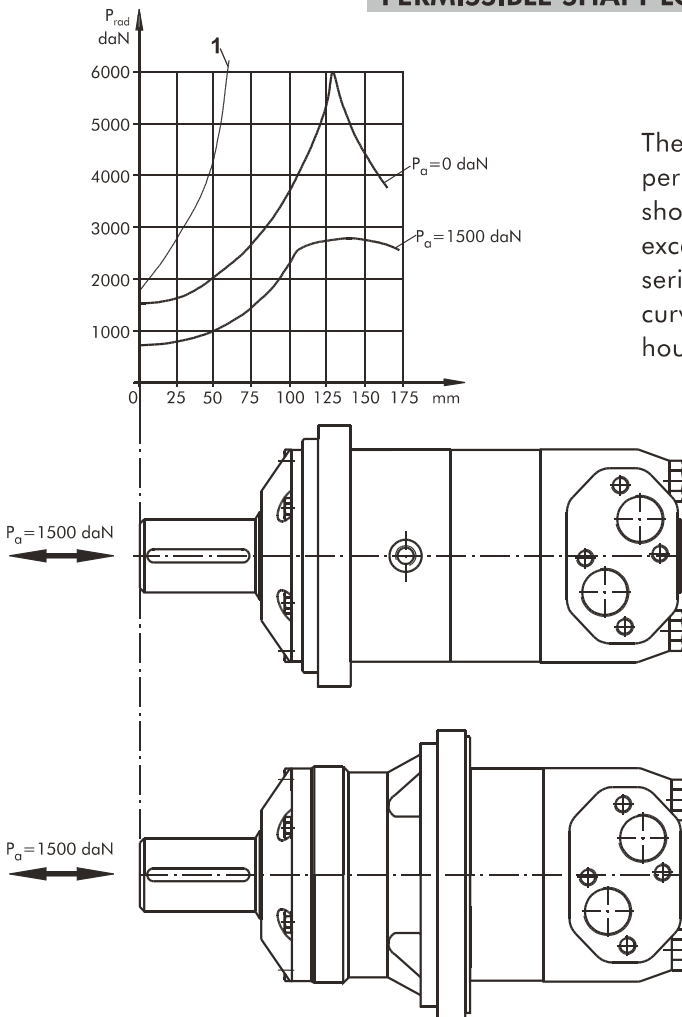

The output shaft runs in tapered bearings that permit high axial and radial forces. Curve "1" shows max. radial shaft load. Any shaft load exceeding the values quoted in the curve will seriously reduce motor life. The two other curves apply to a B10 bearing life of 3000 hours at 200 RPM.

DIMENSIONS AND MOUNTING DATA

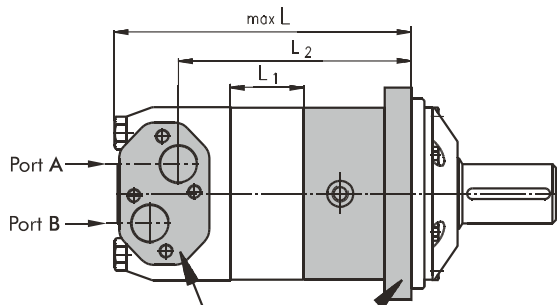

Porting

Side Ports

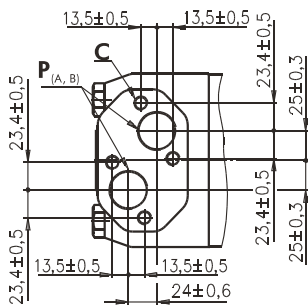

- C:** 4xM12- 12 mm depth
- P_(A,B):** 2xG1 - 20 mm depth
- T:** G 1/4 - 12 mm depth

Standard Rotation
Viewed from Shaft End
Port A Pressurized - CW
Port B Pressurized - CCW

Reverse Rotation
Viewed from Shaft End
Port A Pressurized - CCW
Port B Pressurized - CW

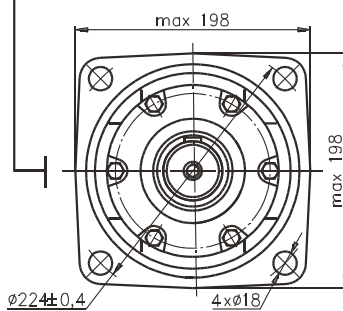
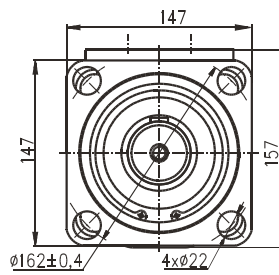
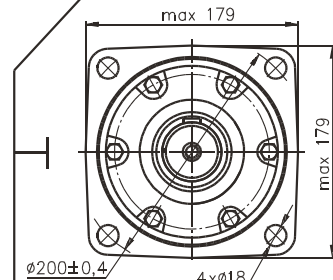

Mounting

Square Mount (4 Holes)

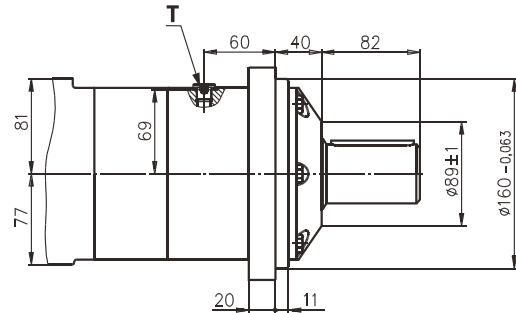

C SAE C Mount

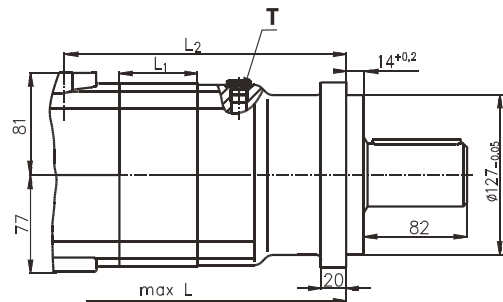

W Wheel Mount

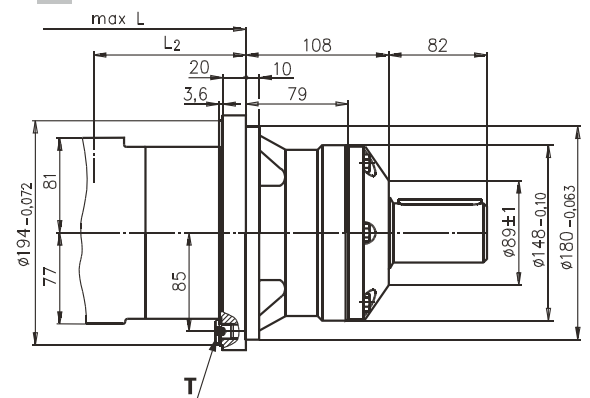

Type	L, mm	L ₂ , mm	Type	L, mm	L ₂ , mm	Type	L, mm	L ₂ , mm	*L ₁ , mm
MV 315	214,5	160	MVC 315	238,25	184,26	MVW 315	146	92	21,5
MV 400	221,5	167	MVC 400	245,25	191,26	MVW 400	153	99	28,5
MV 500	229,5	175	MVC 500	253,25	199,26	MVW 500	161	107	36,5
MV 630	240,0	186	MVC 630	263,75	209,76	MVW 630	172	118	47,0
MV 800	254,0	200	MVC 800	277,75	223,76	MVW 800	185	132	61,0

* The width of the gerolor is 4 mm greater than L₁.

DIMENSIONS AND MOUNTING

S Short Mount

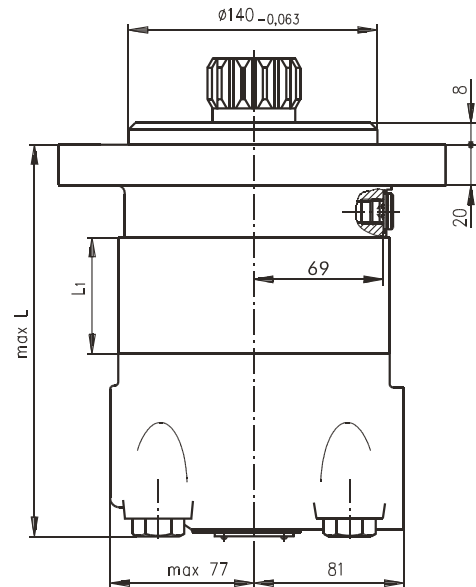
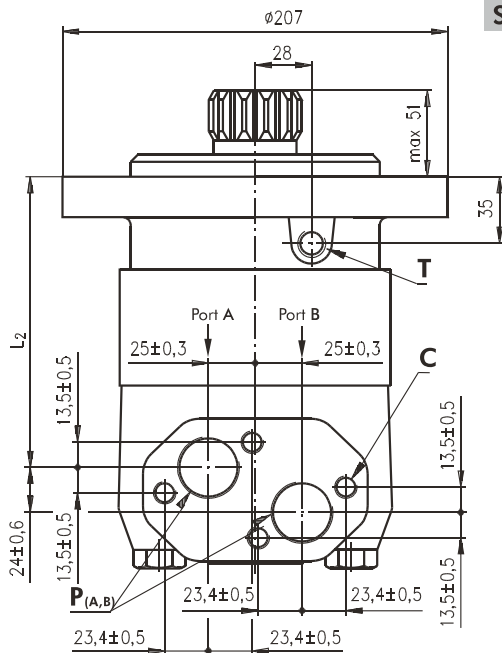

Type	L, mm	*L ₁ , mm	L ₂ , mm
MVS 315	171	22,0	117
MVS 400	179	29,0	124
MVS 500	186	37,0	132
MVS 630	197	47,5	143
MVS 800	211	61,5	157

C: 4xM12- 12 mm depth
P_(A,B): 2xG1 - 20 mm depth
T: G 1/4 - 12 mm depth

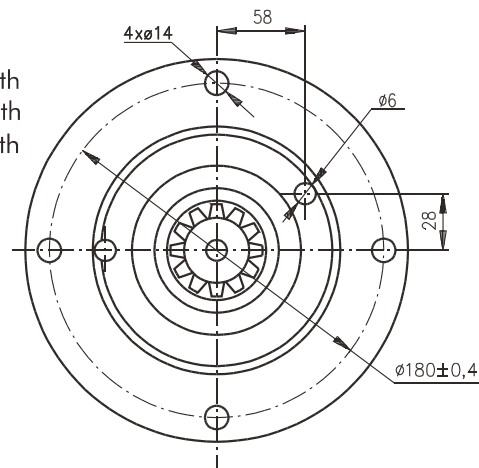

* The width of the gerolor is 4 mm greater than L₁.

Standard Rotation

Viewed from Shaft End

Port A Pressurized - CW

Port B Pressurized - CCW

Reverse Rotation

Viewed from Shaft End

Port A Pressurized - CCW

Port B Pressurized - CW

DIMENSIONS OF THE ATTACHED COMPONENT

MVS

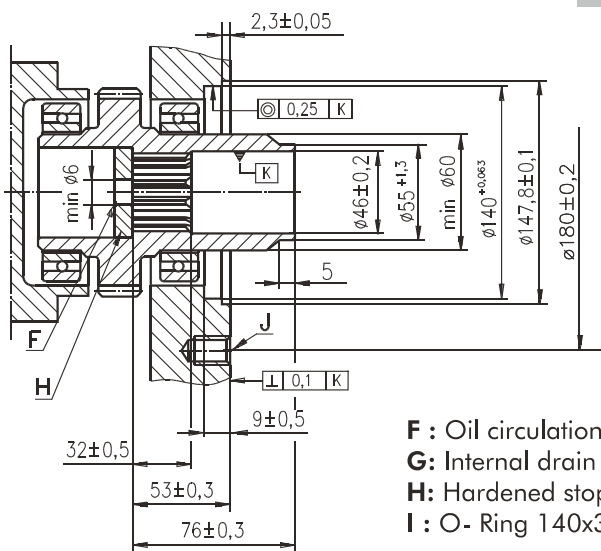

F: Oil circulation hole
G: Internal drain channel
H: Hardened stop plate
I: O- Ring 140x3mm

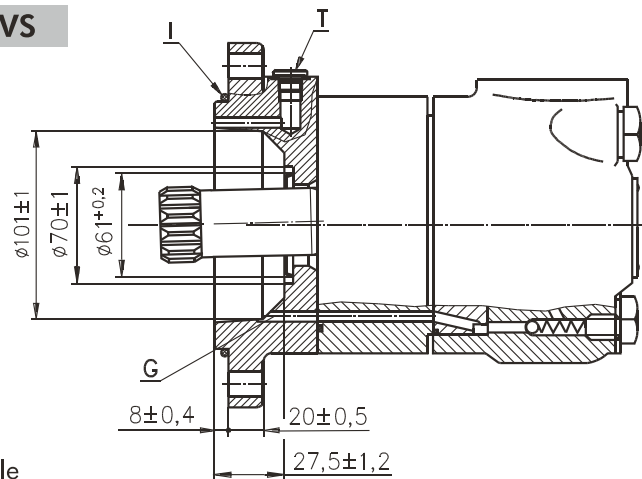

J: 4xM12-18 mm depth, 90°
T: Drain connection G1/4 - 12 mm depth

DIMENSIONS AND MOUNTING

V Very Short Mount

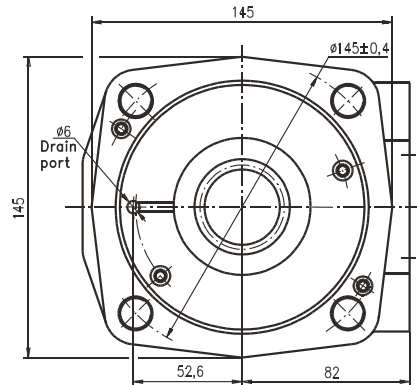
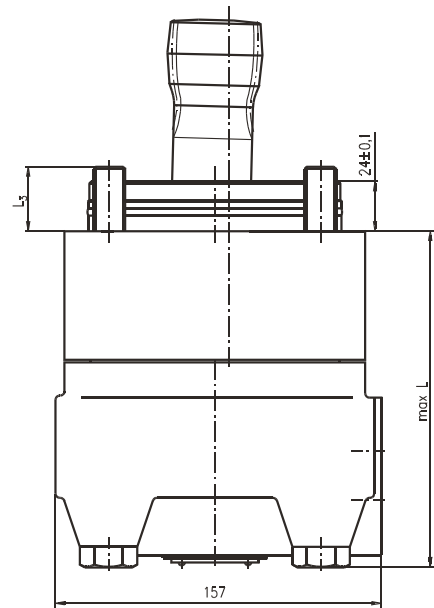
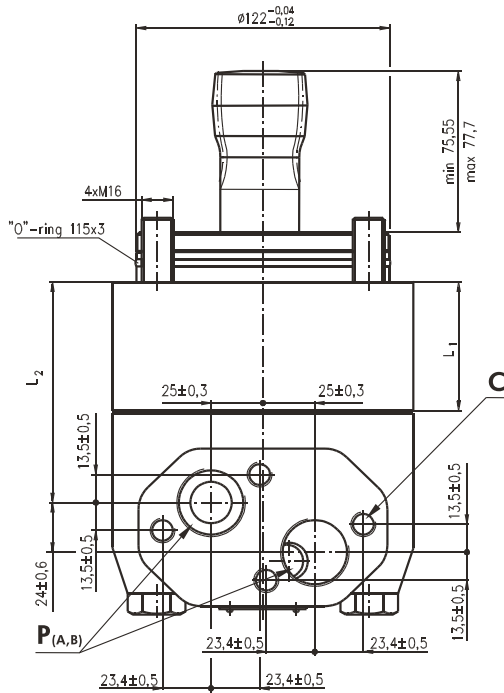

C: 4xM12- 12 mm depth
P_(A,B): 2xG1 - 20 mm depth

Type	L, mm	*L ₁ , mm	L ₂ , mm	L ₃ , mm
MVV 315	121,5	22,0	68,0	29,5
MVV 400	128,5	29,0	75,0	32,5
MVV 500	136,5	37,0	83,0	34,5
MVV 630	147,0	47,5	93,0	34,0
MVV 800	161,0	61,5	107,5	30,0

Standard Rotation
 Viewed from Shaft End
 Port A Pressurized - CW
 Port B Pressurized - CCW

Reverse Rotation
 Viewed from Shaft End
 Port A Pressurized - CCW
 Port B Pressurized - CW

* The width of the gerolor is 4 mm greater than L₁.

DIMENSIONS OF THE ATTACHED COMPONENT

MVV

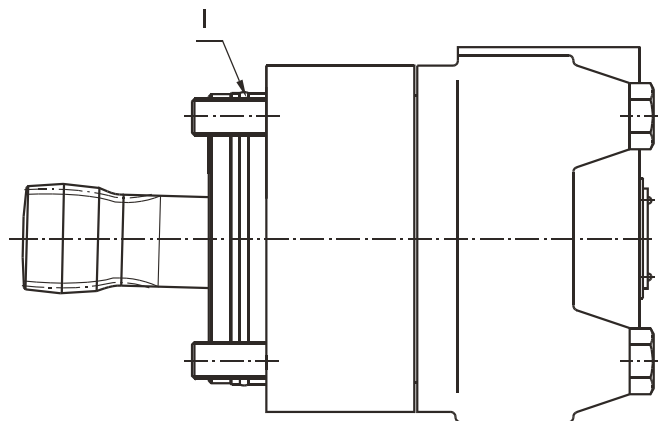
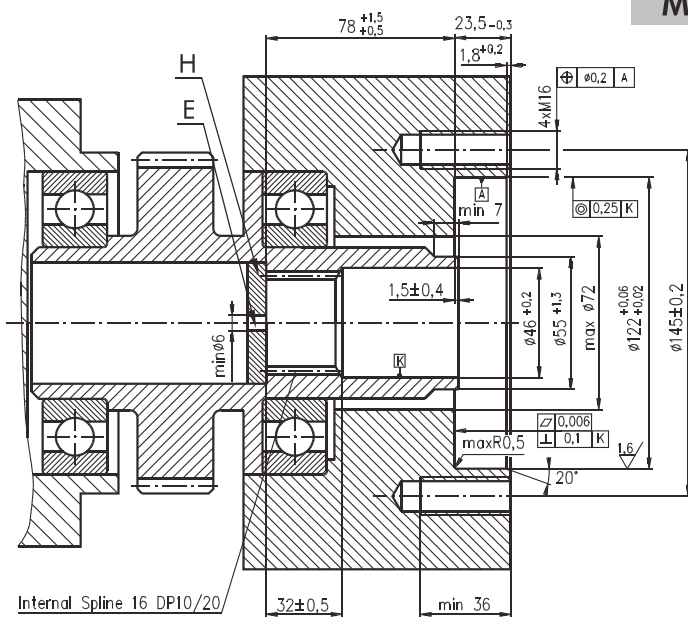

Internal Spline 16 DP10/20
 ANS B92.1-1976, cl.5

E: External drain channel
H: Hardened stop plate
I: O- Ring 115x3mm

DRAIN CONNECTION

A drain line ought to be used when pressure in the return line can exceed the permissible pressure. It can be connected:

- For MVS at the drain port of the motor;
- For MVV at the drain connection of the attached component. The maximum pressure in the drain line is limited by the attached component and its shaft seal.

The drain line must be possible for oil to flow freely between motor and attached component and must be led to the tank. The maximum pressure in the drain line is limited by the attached component and its seal.

INTERNAL SPLINE DATA FOR THE ATTACHED COMPONENT

Standard ANSI B92.1-1976, class 5
 $[m=2.54; \text{corrected } x.m = +1,0]$

Fillet Root Side Fit		mm
Number of Teeth	z	16
Diametral Pitch	DP	10/20
Pressure Angle		30°
Pitch Dia.	D	40,640
Major Dia.	D _{ri}	45,2 ^{+0,4}
Minor Dia.	D _i	38,5 ^{+0,039}
Space Width [Circular]	Lo	5,18±0,037
Fillet Radius	R	0,4
Max. Measurement between Pin	L	32,47 ^{+0,15}
Pin Dia.	d	5,5±0,001

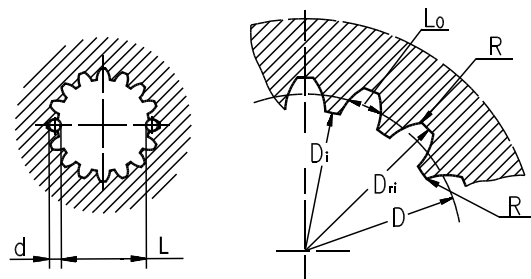

Hardening Specification:

HRC 60±2

HRC 52

0,7±0,2 mm effective case depth

Material 20 MoCr4 DIN 17210 or better

MOTOR WITH TACHO CONNECTION

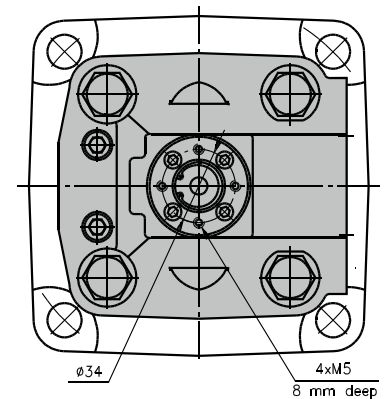
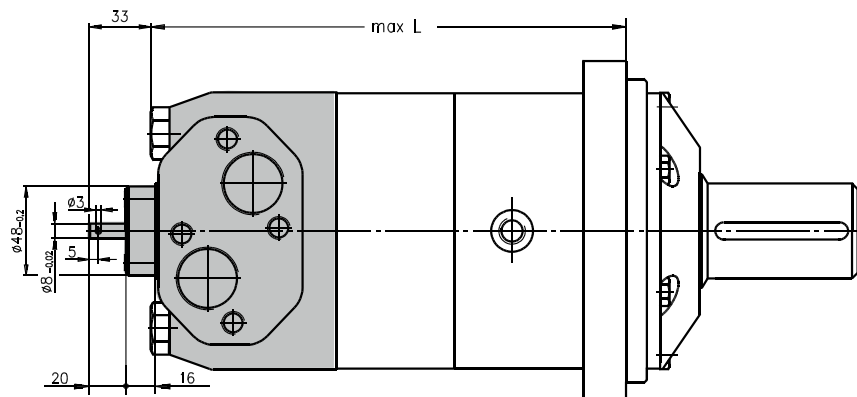

SHAFT EXTENSIONS

C - $\varnothing 50$ straight, Parallel key A14x9x70 DIN 6885

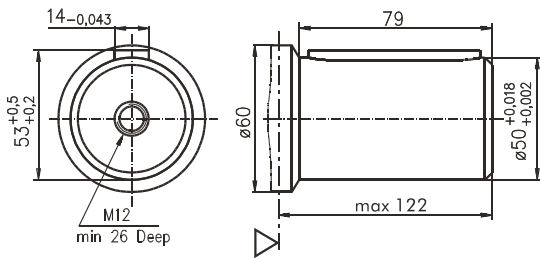

CO - $\varnothing 2\frac{1}{4}$ " [57,15] straight, Parallel key $\frac{1}{2}$ " x $\frac{1}{2}$ " x $2\frac{1}{4}$ " BS46

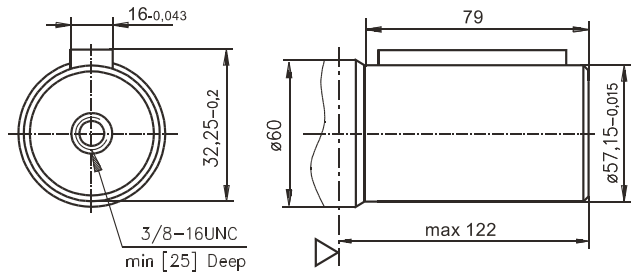

SH - $\varnothing 2\frac{1}{8}$ " splined, 16 DP 8/16 ANSI B92.1-1976

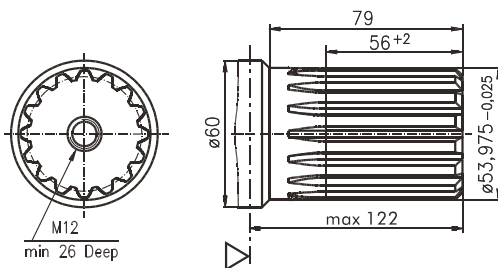

▽ - Motor Mounting Surface

K - tapered 1:10, Parallel key B16x10x32 DIN 6885

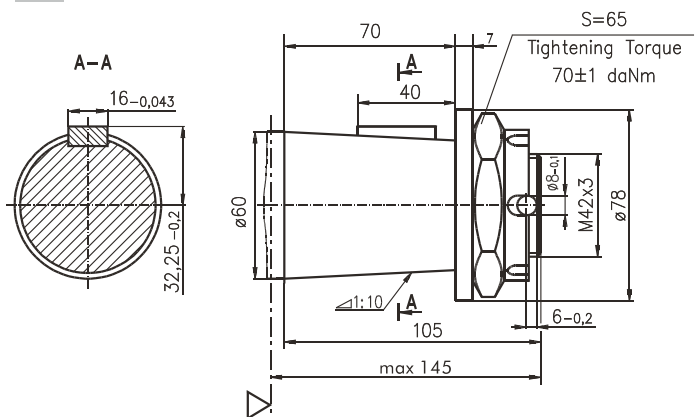

ORDER CODE

	1	2	3	4	5
MV					

Pos. 1 - Mounting Flange

omit - Square mount, four holes

C	- SAE C mount
W	- Wheel mount
S	- Short mount
V	- Very short mount

Pos. 2 - Displacement code

315	- 314,5 [cm ³ /rev]
400	- 400,9 [cm ³ /rev]
500	- 499,6 [cm ³ /rev]
630	- 629,1 [cm ³ /rev]
800	- 801,8 [cm ³ /rev]

Pos. 3 - Shaft extensions*

C	- $\varnothing 50$ straight, Parallel key A14x9x70 DIN6885
CO	- $\varnothing 2\frac{1}{4}$ " straight, Parallel key $\frac{1}{2}$ " x $\frac{1}{2}$ " x $2\frac{1}{4}$ " BS46
SH	- $\varnothing 2\frac{1}{8}$ " splined, ANSI B92.1-1976
K	- $\varnothing 60$ tapered 1:10, Parallel key B16x10x32 DIN6885

Pos. 4 - Special Features (see page 50)

Pos. 5 - Design Series

omit - Factory specified

NOTES:

* The permissible output torque for shafts must not be exceeded!

The hydraulic motors are mangano- phosphatized as standard.

MOTOR SPECIAL FEATURES

Special Feature Description	Order Code	Motor type			
		MS	MSY	MT	MV
Motor for Speed Sensor*	RS	○	○	○	○
Tacho Connection**	T	○	○	○	○
Low Leakage	LL	○	○	○	○
Low Speed Valving	LSV	○	○	○	○
Free Running	FR	○	○	○	○
Reverse Rotation	R	○	○	○	○
Paint***	P	○	○	○	○
Corrosion Protected Paint***	PC	○	○	○	○
Check Valves		S	S	S	S

- Optional
- S Standard

* for sensor ordering see pages 51-52.

** only for side ports.

*** color at customer's request.

MOTORS WITH SPEED SENSOR

MS(Y)...RS

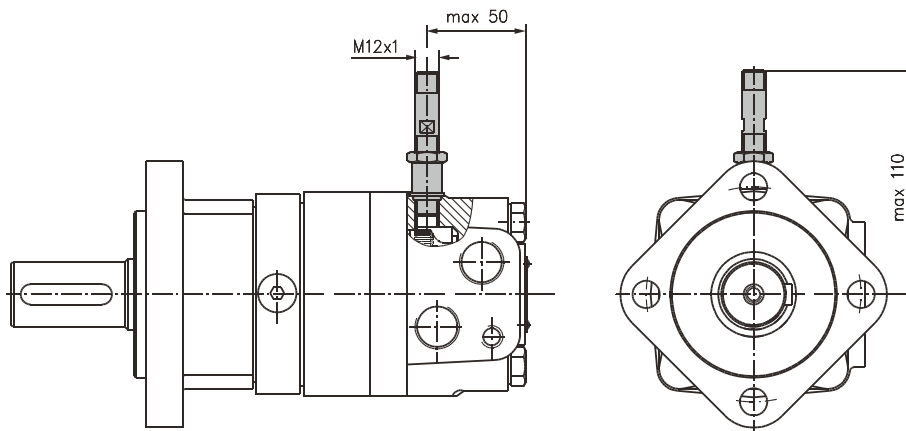

MT...RS

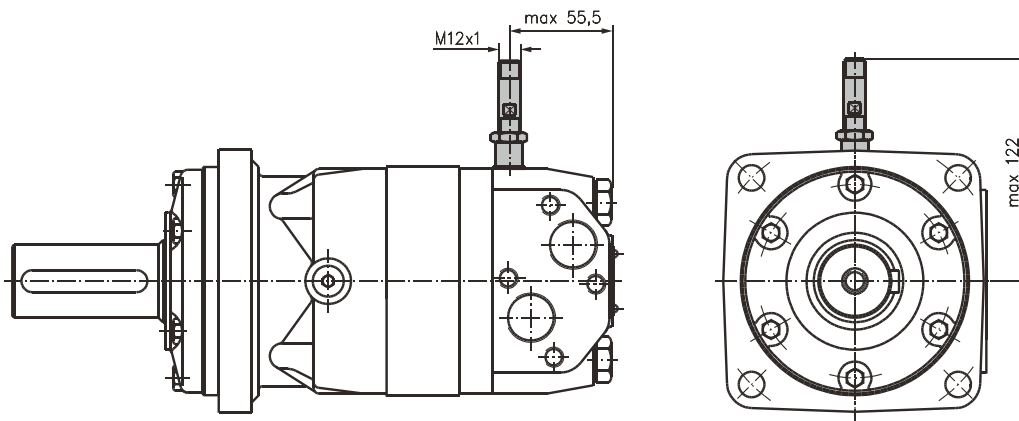

MV...RS

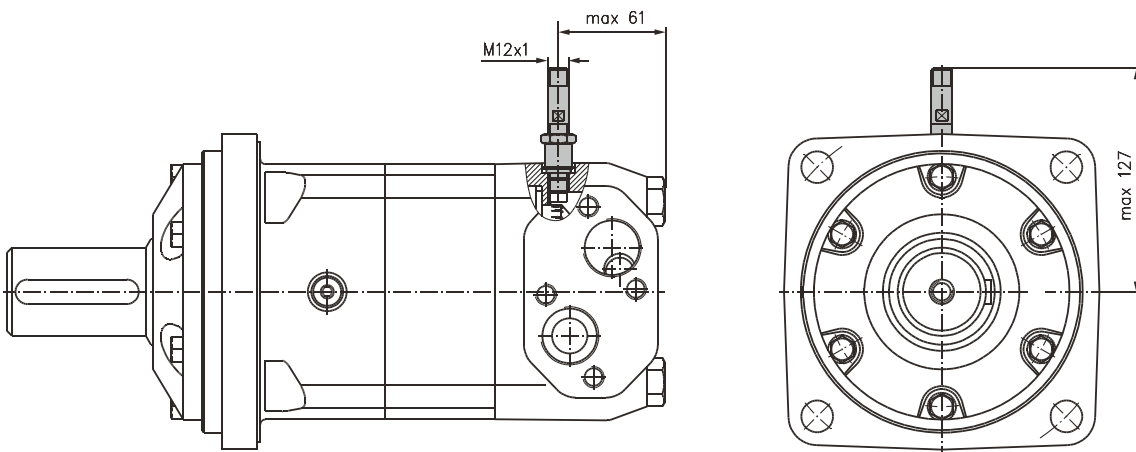

TECHNICAL DATA OF THE SPEED SENSOR

Technical data

Frequency range	3...20 000 Hz
Output	PNP, NPN
Power supply	10...36 VDC
Current input	20 mA (@24 VDC)
Current load	500 mA (@24 VDC; 24°C)
Ambient Temperature	minus 40... plus 125°C
Protection	IP 67
Plug connector	M12-Series
Mounting principle	ISO 6149

Output signal

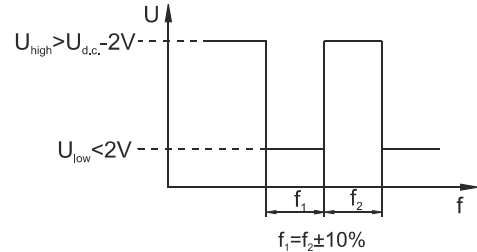

Load max.: $I_{high} = I_{low} < 50\text{mA}$
 No load current, max: 20 mA

Motor type	MS	MT	MV
Pulses per revolution	54	84	102

Wiring diagrams

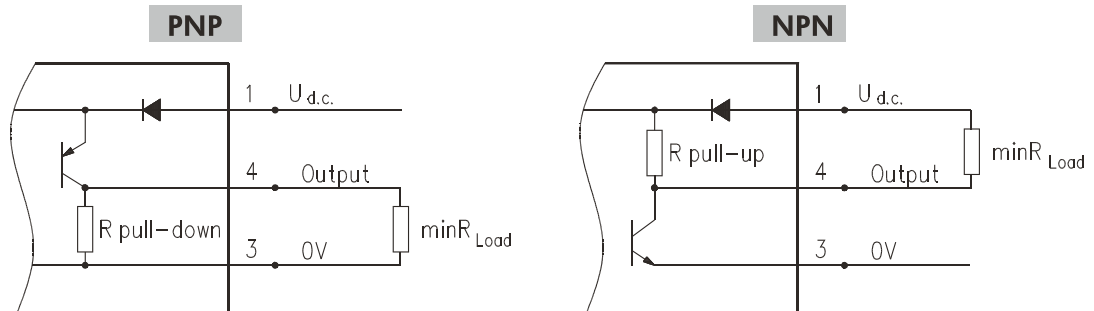

$$R_{Load} = U_{d.c.} / I_{max} (=50\text{mA})$$

Stick type

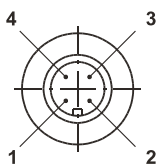

Terminal No.	Connection	Cable Output
1	$U_{d.c.}$	Brown
2	No connection	White
3	0V	Blue
4	Output signal	Black

Order Code for Speed Sensor

Sensor Code	Output type	Electric connection
RSN	NPN	Connector BINDER 713 series
RSP	PNP	Connector BINDER 713 series
PSNL5	NPN	Cable output 3x0,25; 5m long
RSPL5	PNP	Cable output 3x0,25; 5m long

NOTE: *- The speed sensor is not fitted at the factory, but is supplied in a plastic bag with the motor. For installation see enclosed instructions.

HYDRAULIC MOTORS

MOTOR APPLICATION

VEHICLE DRIVE CALCULATIONS

1. Motor speed: n , [min^{-1}]

$$n = \frac{2,65 \times v \times i}{R}$$

v - vehicle speed, [km/h];

R - wheel rolling radius, [m];

i - gear ratio between motor and wheels.

If no gearbox, use $i=1$.

2. Rolling resistance: RR , [daN]

The resistance force resulted in wheels contact with different surfaces:

$$RR = G \times \rho$$

G - total weight loaded on vehicle, [daN];

ρ - rolling resistance coefficient (Table 1).

Table 1

Rolling resistance coefficient In case of rubber tire rolling on different surfaces	
Surface	ρ
Concrete- faultless	0,010
Concrete- good	0,015
Concrete- bad	0,020
Asphalt- faultless	0,012
Asphalt- good	0,017
Asphalt- bad	0,022
Macadam- faultless	0,015
Macadam- good	0,022
Macadam- bad	0,037
Snow- 5 cm	0,025
Snow- 10 cm	0,037
Polluted covering- smooth	0,025
Polluted covering- sandy	0,040
Mud	0,037 ÷ 0,150
Sand- Gravel	0,060 ÷ 0,150
Sand- loose	0,160 ÷ 0,300

3. Grade resistance: GR , [daN]

$$GR = G \times (\sin \alpha + \rho \times \cos \alpha)$$

α - gradient negotiation angle (Table 2)

Table 2

Grade %	α Degrees	Grade %	α Degrees
1%	0° 35'	12%	6° 5'
2%	1° 9'	15%	8° 31'
5%	2° 51'	20%	11° 19'
6%	3° 26'	25%	14° 3'
8%	4° 35'	32%	18°
10%	5° 43'	60%	31°

4. Accelerate force: FA , [daN]

Force FA necessary for acceleration from 0 to maximum speed v and time t can be calculated with a formula:

$$FA = \frac{v \times G}{3,6 \times t}, [\text{daN}]$$

FA - accelerate force, [daN];

t - time, [s].

5. Tractive effort: DP , [daN]

Tractive effort DP is the additional force of trailer. This value will be established as follows:

-acc.to constructor's assessment;

-as calculating forces in items 2, 3 and 4 of trailer; the calculated sum corresponds to the tractive effort requested.

6. Total tractive effort: TE , [daN]

Total tractive effort TE is total effort necessary for vehicle motion; that the sum of forces calculated in items from 2 to 5 and increased with 10 % because of air resistance.

$$TE = 1,1 \times (RR + GR + FA + DP)$$

RR - force acquired to overcome the rolling resistance;

GR - force acquired to slope upwards;

FA - force acquired to accelerate (acceleration force);

DP - additional tractive effort (trailer).

7. Motor Torque: M , [daNm]

Necessary torque moment for every hydraulic motor:

$$M = \frac{TE \times R}{N \times i \times \eta_M}$$

N - motor numbers;

η_M - mechanical gear efficiency (if it is available).

8. Cohesion between tire and road covering: M_w , [daNm]

$$M_w = \frac{G_w \times f \times R}{i \times \eta_M}$$

To avoid wheel slipping, it should be observed the following condition $M_w > M$

f - frictional factor;

G_w - total weight over the wheels, [daN].

Table 3

Surface	Frictional factor f
Steel on steel	0,15 ÷ 0,20
Rubber tire on polluted surface	0,5 ÷ 0,7
Rubber tire on asphalt	0,8 ÷ 1,0
Rubber tire on concrete	0,8 ÷ 1,0
Rubber tire on grass	0,4

9.Radial motor loading: P_{rad} , [daN]

When motor is used for vehicle motion with wheels mounted directly on motor shaft, the total radial loading of motor shaft P_{rad} is a sum of motion force and weight force acting on one wheel.

- G_w - Weight held by wheel;
- P_{rad} - Total radial loading of motor shaft;
- M/R - Motion force.

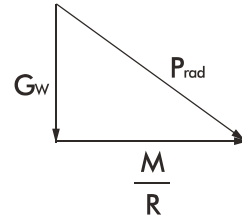

$$P_{rad} = \sqrt{G_w^2 + \left(\frac{M}{R}\right)^2}$$

In accordance with calculated loadings the suitable motor from the catalogue is selected.

DRAINAGE SPACE AND DRAINAGE PRESSURE

Advantages in oil drainage from drain space: Cleaning; Cooling and Seal lifetime prolonging.

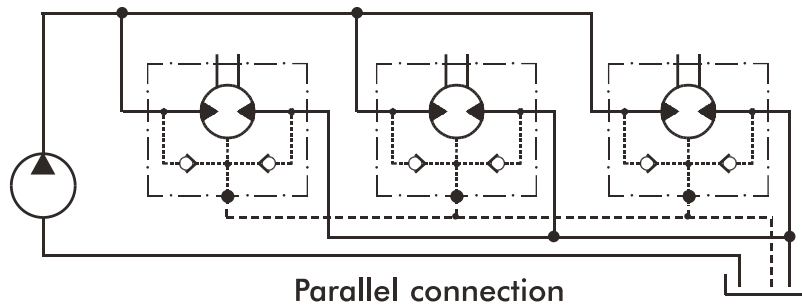
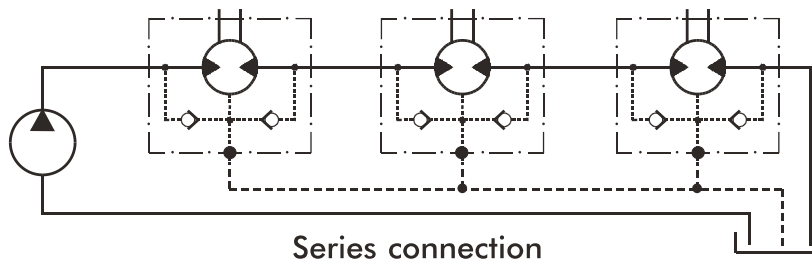

SPOOL VALVE HYDRAULIC MOTORS

The operating principle of the motors is based on an internal gear design, consisting of a stator and rotor through which the output torque and speed are transmitted. The distributor valve is driven synchronously by the rotor through a cardan shaft ensuring that each one of the chambers of the motor are filled and emptied precisely.

PL, RL, RW and HW motors have a Spool Valve.

SPOOL VALVE - The distributor valve has been integrated with the output shaft. The valve has hydrodynamic bearings, and has infinite life when load ratings are not exceeded.

GEAR SET - There are two forms of stator, hence and of gear set:

EPML have plain teeth. These types motors are suitable for long operating periods at moderate pressures- or short operating periods at high pressures.

EPRML have teeth fitted with rollers. The rollers reduce local stress and the tangential reaction forces on the rotor reducing friction to a minimum. This gives long operating life and better efficiency even at continuous high pressures. Roller Gear Sets are recommended for operation with thin oil and for applications having continually reversing loads.

Standard Motor The standard motor mounting flange is located as close to the output shaft as possible. This type of mounting supports the motor close to the shaft load. This mounting flange is also compatible with many standard gear boxes.

Low Leakage **LL** Series hydraulic motors have been designed to operate at the whole standard range of working conditions (pressure drop and frequency of rotation), but with considerable decreased volumetric losses in the drainage ports. Their main purpose is to operate as series-connected motors in hydraulic systems. For this version is permissible decreasing of the maximal torque with up to 5% (at middle speed) and up to 10% (at high speed) in comparison to the standard versions of motors.

Low Speed Valve **LSV** Series hydraulic motors have been designed to operate with normal pressure drop and to ensure smooth run at low speed (up to 200 min^{-1}), as the best security for operation is guaranteed at frequency of rotation $20 \div 50 \text{ min}^{-1}$. They have an increased starting pressure drop and are not recommended for using at pressure less than 40 bar.

Free Running **FR** Series hydraulic motors have been designed to operate with high frequencies of rotation /over than 300 min^{-1} / and low pressure drop. These motors are produced with increased clearance at all friction parts. Additional advantages of "FR" version are prolonging of the life of the hydraulic motors at high frequencies of rotation, as well as the possibility to use them in systems with big variation of the loading. Volumetric efficiency can be affected.